

OZOa - SPECIFICATIONS

MODEL	OZOa
Lithium Ion Battery	Hero 36V 7.8Ah Super 36V 10.5Ah
Net Weight (+-0.5 kg)	22kg 48.5lb
Range Testing conditions: Constant speed of 15k/h 75kg load. Flat road Temperature 20-25°C	Hero 32km 20 miles Electric only 60km 37 miles Pedal assisted Super 40km 25 miles Electric only 75km 47 miles Pedal assisted
Charging Time (H)	Hero 4 hours Super 6 hours
Motor	240W gearless
Max Speed	25 km/h 16 mph
Brakes	Front and rear disk brakes
Tire Size	16"/2-125 pneumatic tires
Tire Air Pressure	35 PSI to 45 PSI
Folded Size L x W x H	137 x 59 x 77 cm 54 x 23 x 30 inches
Open Size L x W x H	137 x 59 x 101.5 cm 54 x 23 x 40 inches
Load Limit	100 kg 220 pounds
Lights	Integral LED front light, rear light
Throttle	Electric Thumb Throttle, pedal assist

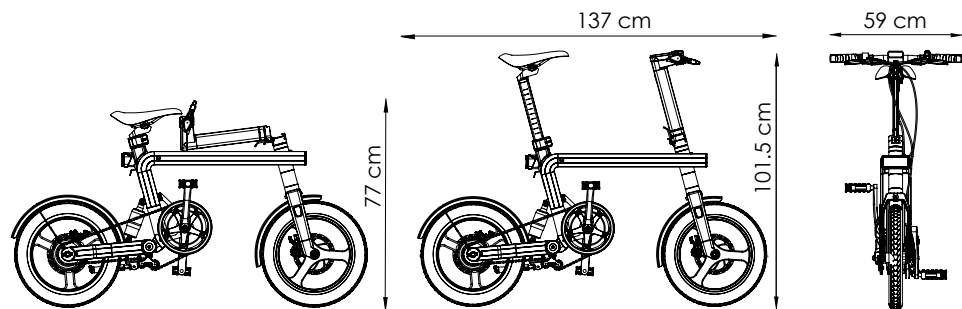

OZOa - SPECIFICATIONS

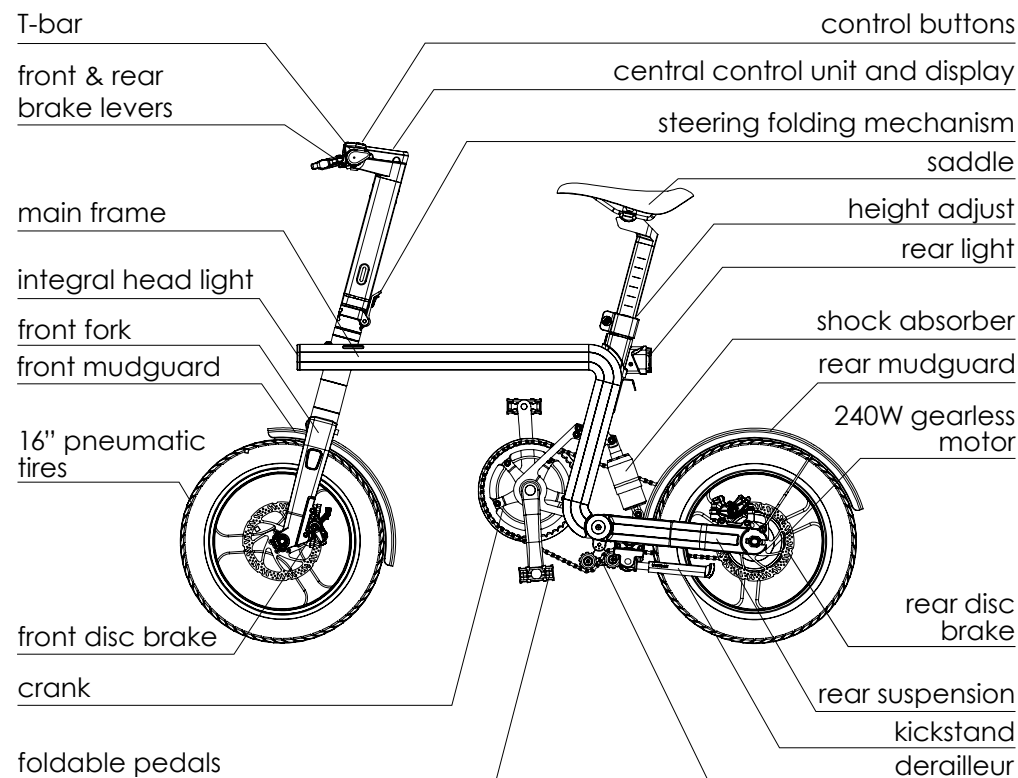

T-BAR RIDER INTERFACE

